

CESAB

spec sheet

CESAB R200

Reach Trucks, 1.2 - 1.6 tonne



CESAB R212 – R216 Truck Specifications

CHARACTERISTICS						
1.1	Manufacturer			CESAB	CESAB	CESAB
1.2	Model			R212	R214	R216
1.3	Drive			Electric	Electric	Electric
1.4	Operator type			Seated	Seated	Seated
1.5	Load capacity/rated load	Q	kg	1200	1400	1600
1.6	Load centre	c	mm	600	600	600
1.8	Load distance, centre of support arm wheel to face of forks	x	mm	449	418	400
1.9	Wheelbase	y	mm	1434	1434	1434
WEIGHT						
2.1	Service weight including battery		kg	2849	2974	3509
2.3	Axle load, mast retracted without load, drive/support arm wheel		kg	1630/1219	1690/1284	2003/1506
2.4	Axle load, mast extended with load, drive/support arm wheel		kg	719/3330	444/3930	424/4685
2.5	Axle load, mast retracted with load, drive/support arm wheel		kg	1340/2709	1300/3074	1580/3529
WHEELS AND TYRES						
3.1	Drive/support arm wheel			Polyurethane	Polyurethane	Polyurethane
3.2	Wheel size front		mm	Ø310x140	Ø310x140	Ø310x140
3.3	Wheel size rear		mm	Ø285x85	Ø285x85	Ø285x85
3.5	Wheels, number front/rear (x=driven wheels)			1x/2	1x/2	1x/2
3.7	Track width, rear	b ₁₁	mm	968	968	968
DIMENSIONS						
4.1	Tilt of fork, forward/backward	α / β	deg	-0.5°/2° (mast tilt)	-2°/4*	-2°/4*
4.2	Height, mast lowered	h ₁	mm	1930*	2057*	2190*
4.3	Free lift	h ₂	mm	1457*	1416*	1549*
4.4	Lift	h ₃	mm	4110*	4360*	4760*
	Lift height	h ₂₃	mm	4150*	4400*	4800*
4.5	Height, mast extended	h ₄	mm	4654*	5040*	5440*
4.7	Height of overhead guard (cab)	h ₆	mm	2166	2166	2166
4.8	Seat height	h ₇	mm	1060	1060	1060
4.10	Height of support arms	h ₈	mm	262	262	262
4.15	Height of lowered forks	h ₁₃	mm	40	40	40
4.19	Overall length	l ₁	mm	2332	2484	2592
4.20	Length to face of forks	l ₂	mm	1182	1334	1442
4.21	Overall width	b ₁	mm	1120	1120	1120
4.22	Fork dimensions	s/e/l	mm	40/100/1150*	40/100/1150*	40/100/1150*
4.23	Fork carriage ISO 2328, class/type A, B			II A	II A	II A
4.25	Width over forks	b ₅	mm	250-720	250-720*	250-720*
4.26	Distance between support arms	b ₄	mm	880	880	880
4.28	Reach distance	l ₄	mm	584	576	495
4.31	Ground clearance, with load, below mast ¹⁾	m ₁	mm	70	70	70
4.32	Ground clearance, centre of wheelbase ¹⁾	m ₂	mm	70	70	70
4.33	Aisle width for pallets 1000 x 1200 crossways	A _{st}	mm	2664	2685	2698
4.34	Aisle width for pallets 800 x 1200 lengthways	A _{st}	mm	2700	2727	2743
4.35	Turning radius	W _a	mm	1649	1649	1649
4.37	Length across support arms	l ₇	mm	1808	1808	1808
PERFORMANCES						
5.1	Travel speed, drive direction with/without load		km/h	10.1/11.2	10.0/11.2	10.0/11.2
	Travel speed, fork direction with/without load		km/h	7.5/9	7.5/9	7.5/9
5.2	Lift speed, with/without load		m/s	0.29/0.42	0.27/0.42	0.25/0.42
5.3	Lowering speed, with/without load		m/s	0.47/0.47	0.50/0.44	0.50/0.44
5.4	Reach speed, with/without load		m/s	0.15/0.16	0.15/0.16	0.15/0.16
5.8	Max. gradeability, with/without load ²⁾		%	15/10 ²⁾	15/10 ²⁾	15/10 ²⁾
5.10	Service brake			Electric	Electric	Electric
ELECTRIC MOTOR						
6.1	Drive motor, rating S2 60 min		kW	7,5	7,5	7,5
6.2	Lift motor rating S3 15%		kW	11	11	11
6.4	Battery voltage, nominal capacity K ₅		V/Ah	48/292-600*	48/292-600*	48/292-600*
6.5	Battery weight, min.		kg	510*	510*	510*
6.6	Energy consumption according to VDI cycle ³⁾		kWh/h			
OTHERS						
8.1	Type of drive control			Variable AC	Variable AC	Variable AC
8.4	Sound level at the driver's ear according to EN 12 053		dB(A)	<70	<70	<70

¹⁾ 15 mm under studs

²⁾ Measured according to company standard

³⁾ Contact your supplier for information

*) Further alternatives are available and will produce other values

All data are based on table configuration. R212: h23 = 4150 mm Triplex mast without sideshift and 275 mm battery compartment.

R214: h23 = 5400 mm with sideshift and 340 mm battery compartment. R216: h23 = 8500 mm with sideshift and 430 mm battery compartment.

Other configurations may give other values. Truck performance and dimensions are nominal and subject to tolerances.

Products and specifications are subject to change without notice.

CESAB R212 – R216 Dimensional Drawings

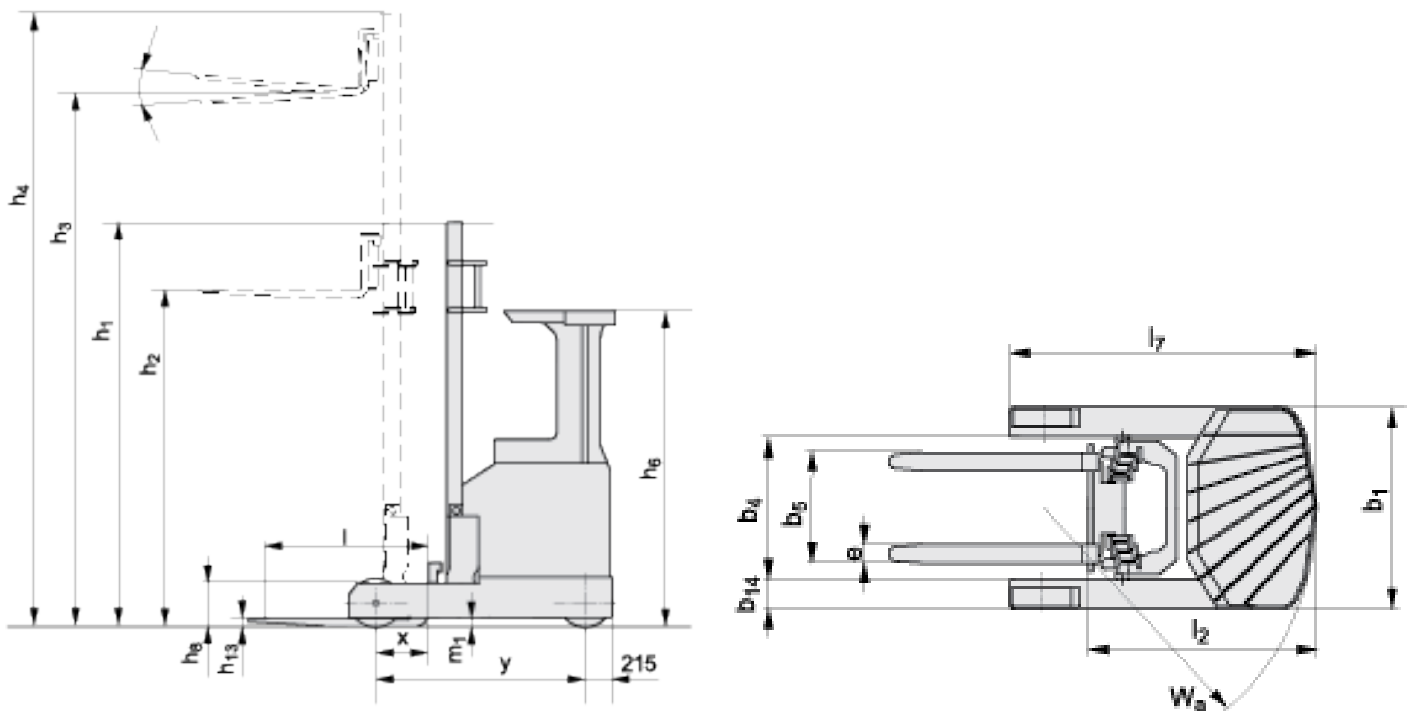

Battery compartments

DIMENSIONS			R212			R214			R216		
Battery compartment depth		mm	275	340	430	275	340	430	275	340	430
1.8	Load distance, centre of support arm wheel to face of forks without sideshift	x mm	449	384	294	418	353	263	400	335	245
	Load distance, centre of support arm wheel to face of forks with sideshift	x mm	394	329	239	380	315	225	362	297	207
4.19	Overall length without sideshift	l_1 mm	2332	2397	2487	2381	2446	2536	2399	2464	2554
	Overall length with sideshift	l_1 mm	2387	2452	2542	2419	2484	2574	2437	2502	2592
4.20	Length to face of forks without sideshift	l_2 mm	1182	1247	1337	1231	1296	1386	1249	1314	1404
	Length to face of forks with sideshift	l_2 mm	1237	1302	1392	1269	1334	1424	1287	1352	1442
4.33	Aisle width for pallets 1000x1200 crossways without sideshift	A_{st} mm	2664	2709	2776	2685	2732	2800	2698	2745	2814
	Aisle width for pallets 1000x1200 crossways with sideshift	A_{st} mm	2702	2750	2819	2712	2760	2830	2725	2774	2844
4.34	Aisle width for pallets 800x1200 lengthways without sideshift	A_{st} mm	2700	2758	2840	2728	2786	2868	2744	2803	2885
	Aisle width for pallets 800x1200 lengthways with sideshift	A_{st} mm	2749	2808	2890	2762	2821	2903	2778	2837	2920
4.35	Turning radius	W_a mm	1649	1649	1649	1649	1649	1649	1649	1649	1649
6.4	Battery voltage, nominal capacity K_s	V/Ah	48/310	48/465	48/620	48/310	48/465	48/620	48/310	48/465	48/620
6.5	Battery weight, min.	kg	510	610	780	510	610	780	510	610	780

Mast Specifications

DIMENSIONS			Triplex Freelift												
Lift height		h_{23} mm	4150	4400	4500	4800	5400	5700	6000	6300	6750	7000	7500	8000	8500
Lift		h_3 mm	4110	4360	4460	4760	5360	5660	5960	6260	6710	6960	7460	7960	8460
R212	Height, mast lowered	h_1 mm	1930	-	2047	2147	2347	-	2647	-	-	-	-	-	-
	Free lift	h_2 mm	1457	-	1574	1674	1874	-	2174	-	-	-	-	-	-
Height, mast extended		h_4 mm	4654	-	5004	5304	5904	-	6504	-	-	-	-	-	-
R214	Height, mast lowered	h_1 mm	-	2067	-	2220	2400	2500	-	2700	-	-	-	-	-
	Free lift	h_2 mm	-	1416	-	1549	1749	1849	-	2049	-	-	-	-	-
Height, mast extended		h_4 mm	-	5050	-	5450	6050	6350	-	6950	-	-	-	-	-
R216	Height, mast lowered	h_1 mm	-	2067	-	2220	2400	2500	-	2742	2991	3074	3241	3408	3574
	Free lift	h_2 mm	-	1416	-	1549	1749	1849	-	2091	2340	2423	2590	2757	2923
Height, mast extended		h_4 mm	-	5050	-	5450	6050	6350	-	6950	7400	7650	8150	8650	9150

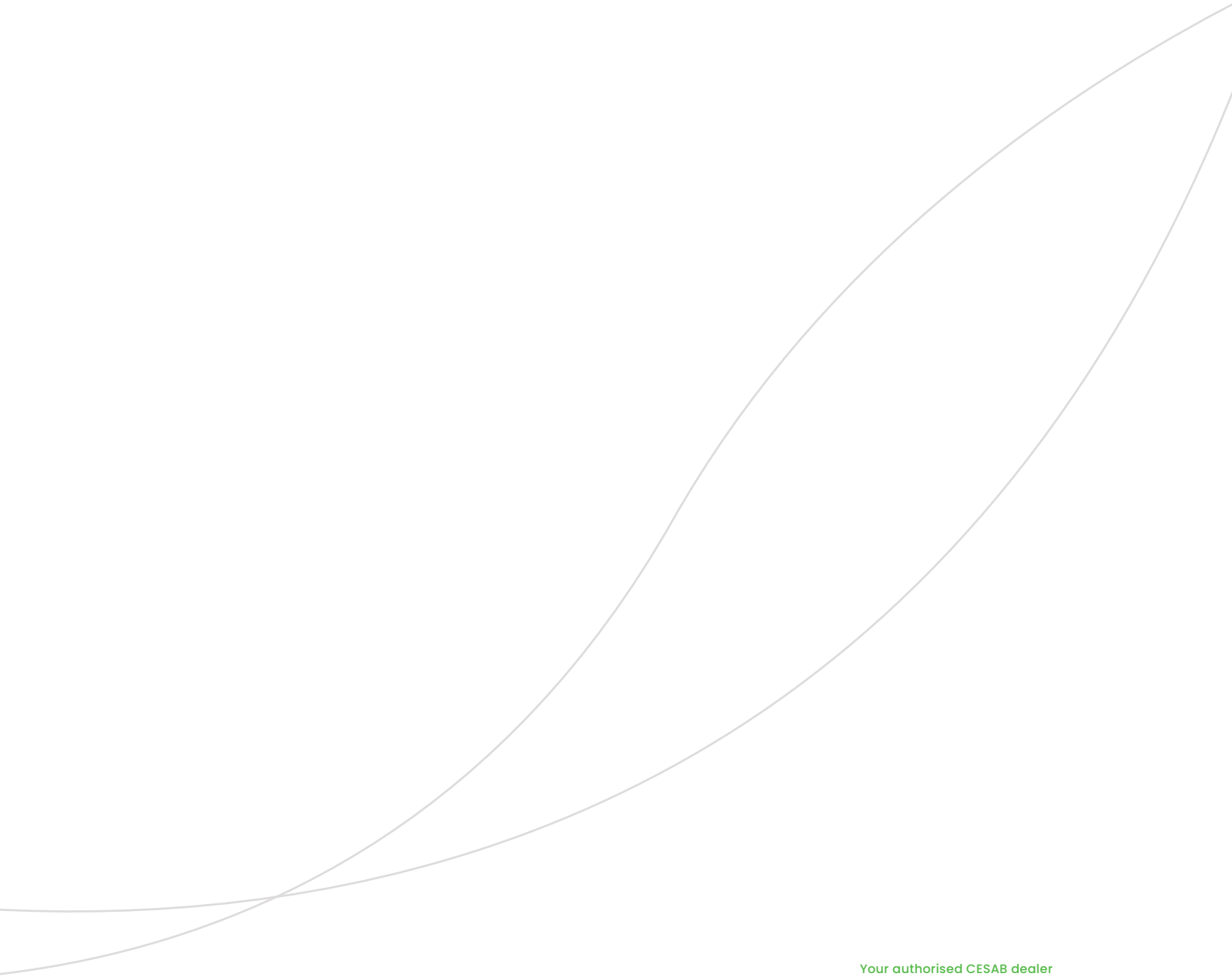

Your authorised CESAB dealer

Pictures may show optional equipment not included in the basic truck price.
The data in this specification sheet was determined based on our standard testing conditions.
Operating performance may vary depending on the actual specification and condition of the truck
as well as the condition of the operating area.

Availability and specifications are determined regionally and are subject to change without notice.
Please consult your authorised CESAB dealership for further details. SPEC_R200_EN_2020 / Ucan V01 -
Copyright CESAB Material Handling Europe.